

# FOLDABLE BASKET

REF : PANPLI00XXX

**+ QUICK AND EASY ASSEMBLY**

**+ SPACE SAVING**

Once used the basket can be folded flat to maximise storage space

**+ MULTI-PURPOSE**

Ideal storage for all products

COMES ALSO AS A  
**MONOBLOCK DESIGN**

**CUSTOM-MADE SIZE OPTION\***  
(minimum order of 50 baskets)



## OPTIONS (Examples)



CASTORS BASE

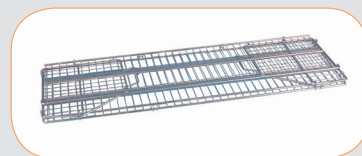
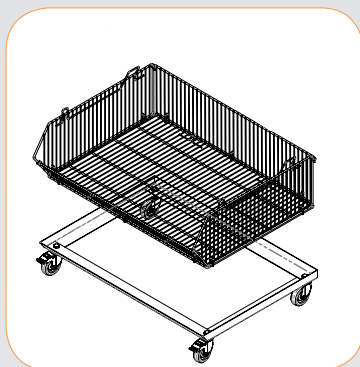

FOLDABLE BASKET

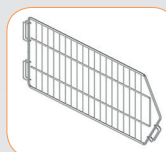

UNIT SEPARATORS



INDUSTRY



LOGISTIC  
DISTRIBUTION



WINE  
PRODUCTION



SHOP FITTINGS



LAUNDRY



DISPLAY  
SYSTEMS



## TECHNICAL DETAILS

### ORDER YOUR CUSTOM-MADE BASKET BY SPECIFYING :

- ✓ the **width**, the **height** and the **depth** that you need
- ✓ the **kind of products to be stored**
- ✓ the **load**

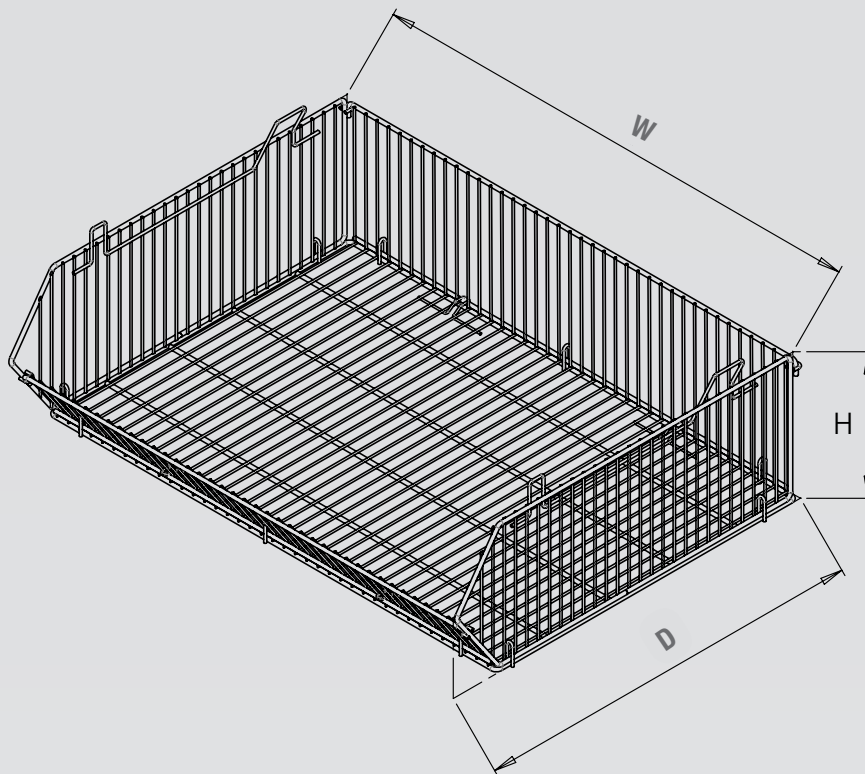

### PRODUCT DETAILS

- ✓ Wire structure
- ✓ Stacked upright

### FINISHING

- ✓ White zinc electroplated finish

### OPTIONS / ACCESSORIES

- ✓ Unit separator
- ✓ Castors base
- ✓ Specific finish (epoxy paint, zinc, powder coating...)