

MONOBLOCK BASKET

REF : PANPLV00XXX

+ RIGID

The basket is resistant to all kinds of load

+ MULTI-PURPOSE

Ideal storage for all products

COMES ALSO AS
FOLDABLE DESIGN

CUSTOM-MADE SIZE OPTION*
(*minimum order of 50 baskets)

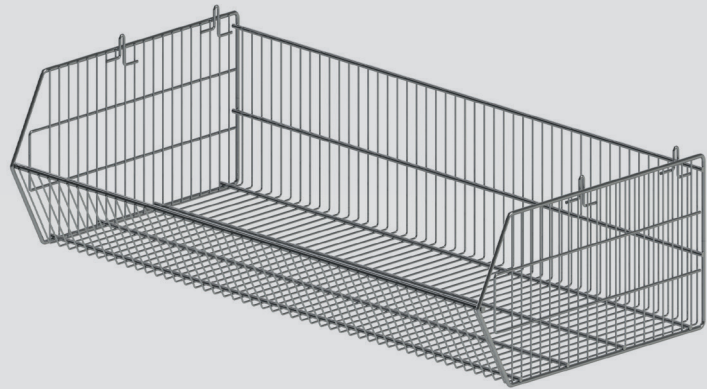

OPTIONS (Examples)



CASTORS BASE

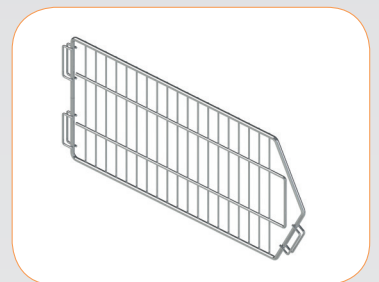
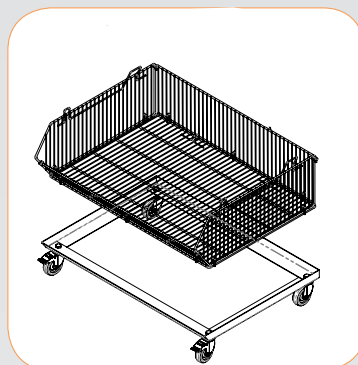

UNIT SEPARATOR



INDUSTRY



LOGISTIC
DISTRIBUTION



WINE
PRODUCTION



SHOP FITTINGS



LAUNDRY



DISPLAY
SYSTEMS



TECHNICAL DETAILS

ORDER YOUR CUSTOM-MADE BASKET BY SPECIFYING :

- ✓ The **width**, the **height** and the **depth** that you need
- ✓ The **kind of products** to be stored
- ✓ The **load**

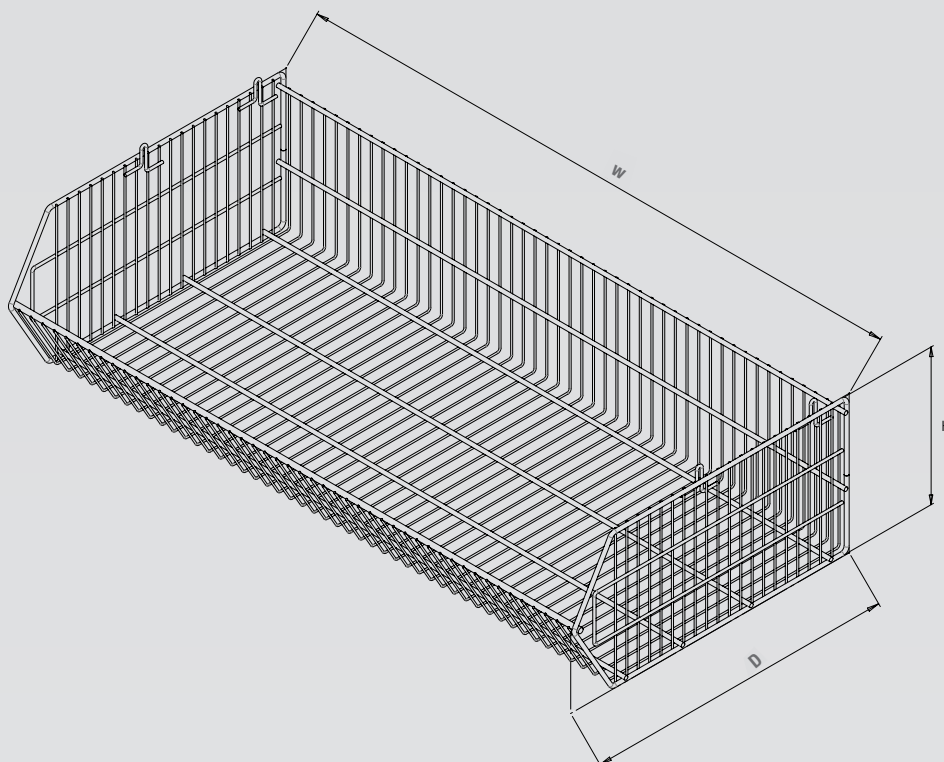

PRODUCT DETAILS

- ✓ Wire structure
- ✓ Stacked upright

FINISHING

- ✓ White zinc electroplated finish

OPTIONS / ACCESSORIES

- ✓ Unit separator
- ✓ Castors base
- ✓ Specific finish (epoxy paint, zinc, powder coating...)