

NEWSPAPER DISPLAY STAND

REF : SUPJOU00001

+ STYLISH

The stand allows the magazine to be displayed front facing which enables optimum visibility

+ EASY TO HANDLE

Thanks to the lightweight frame, the wheels and the gripping handle, the stand is easy to manage

+ CUSTOMIZABLE

Large choice of options available in order to make your own unique display stand (colours, front panel for product display or personalised adhesive label)

CUSTOM-MADE SIZE OPTION
(minimum order of 50 stands)



registered design

OPTIONS (Examples)



WHEELS

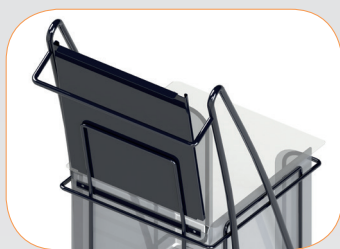

GRIPPING HANDLE



WEATHERPROOF PROTECTION



INDUSTRY



LOGISTIC DISTRIBUTION



WINE PRODUCTION



SHOP FITTINGS



LAUNDRY



DISPLAY SYSTEMS



TECHNICAL DETAILS

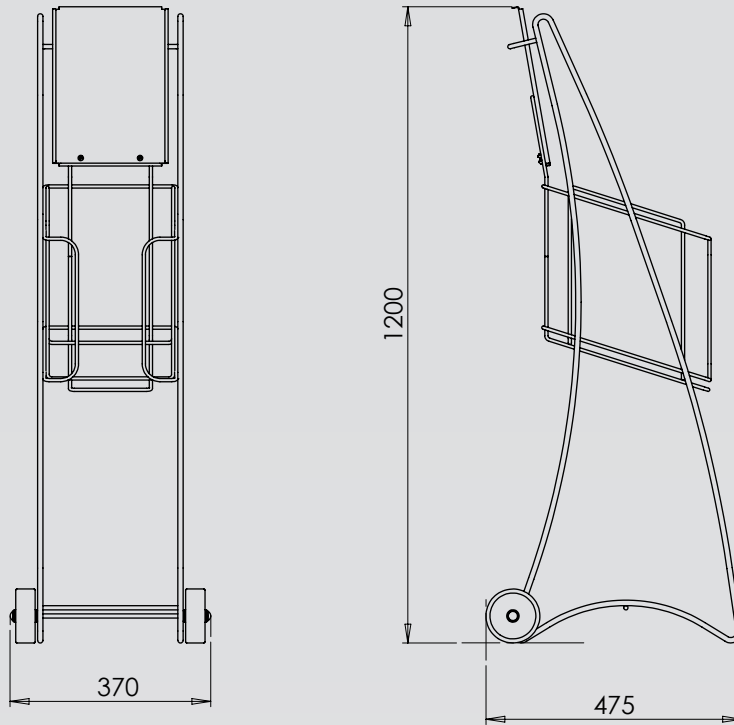

LOAD

- ✓ Empty : 7 Kg
- ✓ Full: 15 Kg (max)

PRODUCT DETAILS

- ✓ Compartment height: 300 mm / A4 format
- ✓ Front identification plate : A4 format
- ✓ Gripping handle

WHEELS

- ✓ 2 fixed wheels : Ø 100 mm

FINISHING

- ✓ Epoxy pain (choice of colours)

OPTIONS / ACCESSORIES

- **Weatherproof protection made of :**
 - ✓ soft cover
 - ✓ plexi box
 - ✓ display front plexi protection
- **Wheels**