

BAC FOUILLE REPLIABLE GOUPIL

REF : PANPLV00072

+ FONCTIONNEL

Idéal pour présenter vos produits en vrac

+ CONFORT / PRATIQUE

Tablette amovible réglable en hauteur en fonction de votre utilisation

+ REPLIABLE

Faible encombrement pour le stockage

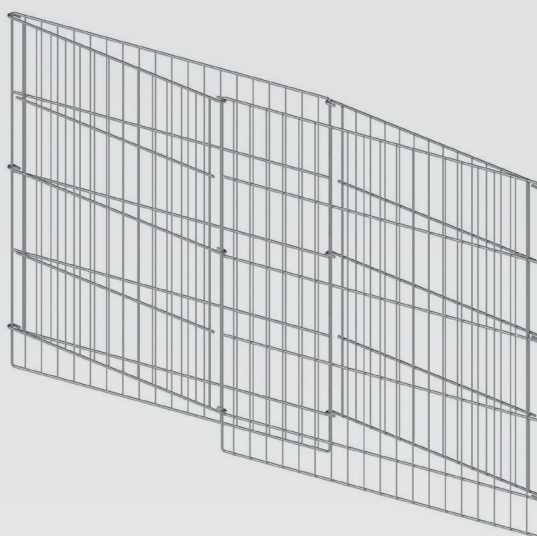
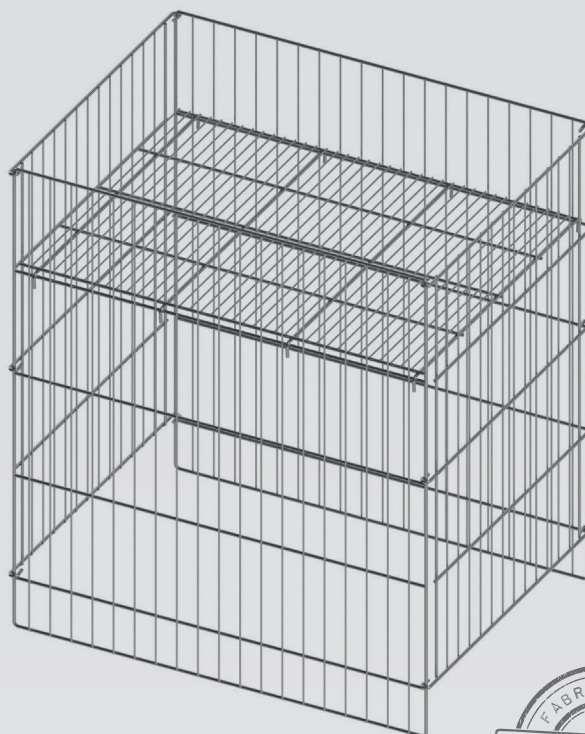

BAC FOUILLE REPLIÉ



INDUSTRIE
S/T



LOGISTIQUE
MANUTENTION



VINICOLE



AMÉNAGEMENT
MAGASIN



BLANCHISSERIE



PLV



CARACTERISTIQUES TECHNIQUES

PANPLV00072	Dimensions utiles	Dimensions extérieures
Largeur	780 mm	800 mm
Profondeur	574 mm	600 mm
Hauteur	785 mm maxi	900 mm

CONCEPTION**

- ✓ Ossature en fil de Ø6 mm
- ✓ Treillis en fil Ø3 mm et 6 mm maille 200 x 40 mm

FINITION

- ✓ Electro zingage blanc

**Sur la base du PANPLV00072